

# CITY OF NAPOLEON GENERAL PERMIT APPLICATION

THIS APPLICATION IS FOR RESIDENTAL CONSTRUCTION INCLUDING BUILDING, ELECTRICAL, PLUMBING, MECHANICAL, DEMOLITIONS, REMODELING.

DATE: 12/10/07 JOB LOCATION: 201 Sheffield Ave.

OWNER: Greg Leupp PHONE: (419)

OWNER ADDRESS: 201 Sheffield Ave. CITY: Napoleon ZIP: 43545

CONTRACTOR: M+B Hancock + Son

PHONE #: (419) 683-7249 CELL PHONE# (419) 553-0283

CONTRACTOR LICENSED WITH THE CITY OF NAPOLEON?: YES  NO:

Is any of the above job going to be subcontracted out? Yes  No:

If yes to whom: \_\_\_\_\_

DESCRIPTION OF WORK TO BE PERFORMED: \_\_\_\_\_

ESTIMATED COMPLETION DATE: \_\_\_\_\_

## PLEASE MARK THE TYPE OF WORK YOU WILL BE PERFORMING

- |  |   |
|--|---|
| <input type="checkbox"/> A/C ADD ON 1%                 | <input type="checkbox"/> REMODELING 1%              |
| <input type="checkbox"/> BOILER REPLACEMENT 1%         | <input type="checkbox"/> ROOFING 1%                 |
| <input type="checkbox"/> CURBING                       | <input checked="" type="checkbox"/> SEWER REPAIRS** |
| <input type="checkbox"/> DECKS * 1%                    | <input type="checkbox"/> SIDEWALK*                  |
| <input type="checkbox"/> DRIVEWAY*                     | <input type="checkbox"/> SIDING 1%                  |
| <input type="checkbox"/> ELECTRICAL SERVICE UPGRADE 1% | <input type="checkbox"/> SHED* (under 200 sq ft)    |
| <input type="checkbox"/> ELECTRICAL SERVICE NEW 1%     | <input type="checkbox"/> SHED* (over 200 sqft) 1%   |
| <input type="checkbox"/> SWIMMING POOL* 1%             | <input type="checkbox"/> FENCE*                     |
| <input type="checkbox"/> FURNACE REPLACEMENT 1%        | <input type="checkbox"/> TEMP ELECTRIC 1%           |
| <input type="checkbox"/> ADDITIONS* 1%                 | <input type="checkbox"/> FURNACE NEW 1%             |
| <input type="checkbox"/> WATER TAP (size _____")       | <input type="checkbox"/> WINDOWS /DOORS 1%          |
| <input type="checkbox"/> LAWN METER 1%                 |   |
| <input type="checkbox"/> PLUMBING 1%                   |   |

## 1%- EFFECTIVE JUNE 1, 2007 BOARD OF BUILDING STANDARDS FEE

\*PLEASE INCLUDE A PICTURE SHOWING MEASUREMENTS FROM EXISTING STRUCTURES AND PROPERTY LINES. INDICATING THE TYPE OF WORK YOU WISH TO PERFORM.

\*\* IF WORK REQUIRES GOING INTO THE STREET A STREET BOND IS REQUIRED!

FOR PERMIT COSTS PLEASE FILL OUT REVERSE SIDE.

## PERMIT COST WORKSHEET

JOB	BASE FEE	1% BBS FEE =	PERMIT TOTAL
SIDING (only) TOTAL SQ _____ X 1.00 = _____ +	\$5.00 +	1% =	
ROOFING (only) TOTAL SQ _____ X 1.00 = _____ +	\$5.00 +	1% =	
WINDOWS / DOORS(only) # _____ X 1.00 = _____ +	\$5.00 +	1% =	
ELECTRICAL # OF CIRCUITS _____ X 3.00 = _____ +	\$15.00 +	1% =	
ELECTRICAL SERVICE UPGRADE	\$15.00 +	1% =	
PLUMBING (INSIDE) replacing/ repairs	\$10.00 +	1% =	
SEWER (OUTSIDE)	\$25.00	N/A	25 <sup>00</sup>
WATER HEATER	\$5.00 +	1% =	
SHED UNDER 200 SQ FT (over 200 see chart)	\$5.00	N/A	
FURNACE OR A/C (REPLACEMNT)	\$5.00 +	1% =	
DEMOLITION (only)	\$30.00	N/A	
SIDEWALK REPLACEMENT/ NEW	\$25.00	N/A	
DRIVEWAY	\$25.00	N/A	

ALL CONSTRUCTION, ALTERATIONS, REMODELING, SHEDS, DECKS, & FENCES NOT LISTED ABOVE IS BASED ON COST OF WORK BEING PERFORMED.

COST OF WORK \$ \_\_\_\_\_ (SEE CHART) permit fee \$ \_\_\_\_\_ +1 % = \$ \_\_\_\_\_

0.00	-	250.00	0.00	11,000.00	-	11,999.00	25.00
250.00	-	999.00	10.00	12,000.00	-	12,999.00	26.00
1,000.00	-	1,999.00	12.00	13,000.00	-	13,999.00	27.00
2,000.00	-	2,999.00	14.00	14,000.00	-	14,999.00	28.00
3,000.00	-	3,999.00	16.00	15,000.00	-	15,999.00	29.00
4,000.00	-	4,999.00	18.00	16,000.00	-	16,999.00	30.00
5,000.00	-	5,999.00	19.00	17,000.00	-	17,999.00	31.00
6,000.00	-	6,999.00	20.00	18,000.00	-	18,999.00	32.00
7,000.00	-	7,999.00	21.00	19,000.00	-	19,999.00	33.00
8,000.00	-	8,999.00	22.00	20,000.00	-	20,999.00	34.00
9,000.00	-	9,999.00	23.00	21,000.00	-	21,999.00	35.00
10,000.00	-	10,999.00	24.00	22,000.00	-	22,999.00	36.00
				Over 22,999		Please Call	

\*OTHER FEES NOT LISTED  
MAY APPLY

**TOTAL PERMIT COSTS \$** 25<sup>00</sup>

INSTALLED BY: HANCOCK & SONS  
 DATE INSTALLED: 11-29-07  
 INSPECTED BY: MARTY CROSSLAND

No. 937 811E  
 Engineer's Computation Pad  
**STAEDTLER**®

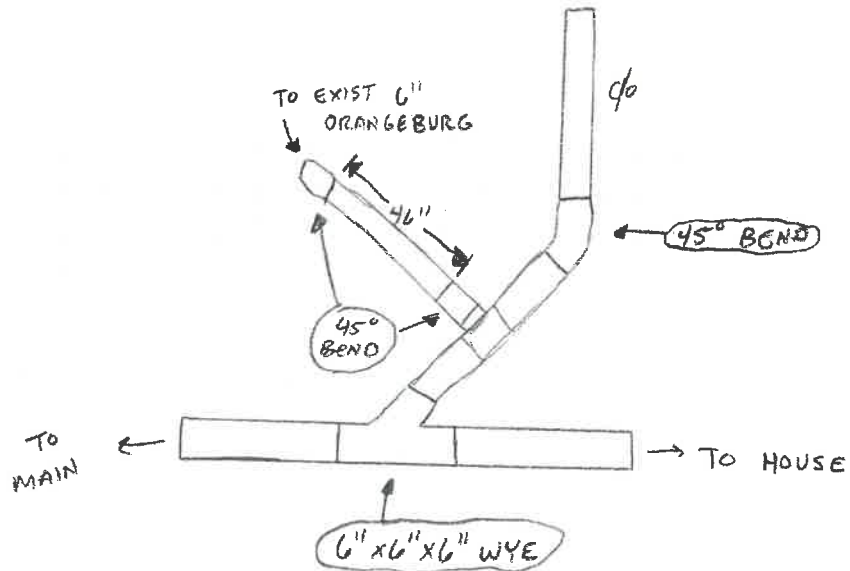
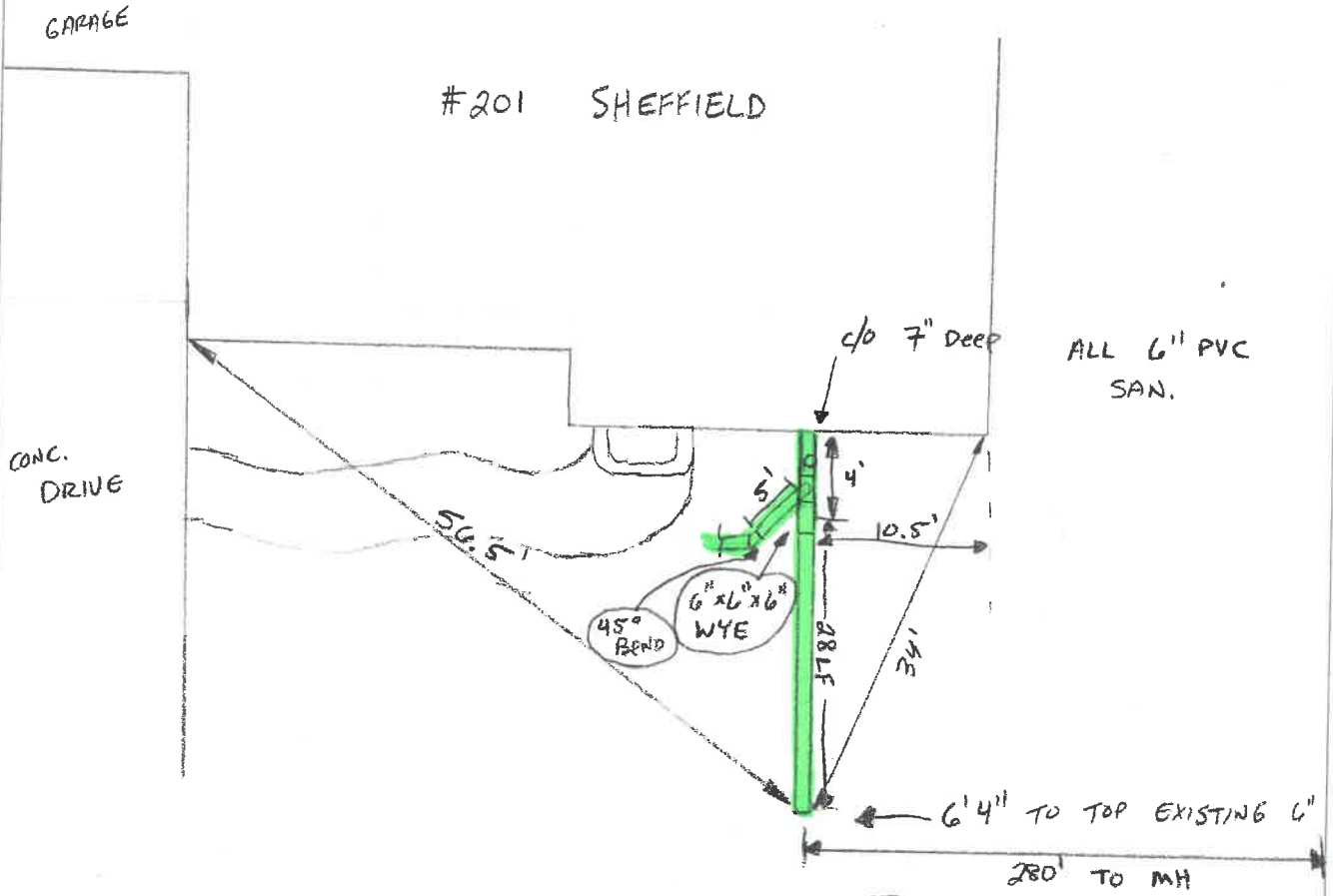





# CITY OF NAPOLEON

**BUILDING & ZONING DEPARTMENT**  
255 West Riverview Avenue, P. O. Box 151 Napoleon, OH 43545  
Tom Zimmerman, Building Commissioner/Zoning Admin  
Telephone: 419/592-4010 Fax: 419/599-8393  
[www.napoleonohio.com](http://www.napoleonohio.com)

December 10, 2007

Mr. Hancock & Son, LTD  
21216 State Route 34  
Stryker, OH 43557

RE: 201 Sheffield Ave.

Mr. Hancock:

It has become aware to the Building Department that you were working within the City limits at 201 Sheffield Ave., without pulling the proper permits nor are you registered to work as a contractor within the City limits. Please fill out the enclosed applications and forward to my office along with \$50.00 (\$25 for sewer permit and \$25 for contractor registration fee).

In the event proper permits are not applied for in advance for any future work the City as the right to revoke your Contractor License and you would not be permitted to work within the City of Napoleon limits.

If you should have any questions feel free to give my office a call.

Thank you,

Tom Zimmerman  
Building Official

cc: file



INSTALLED BY: HANCOCK & SONS  
DATE INSTALLED: 11-29-07  
INSPECTED BY: MARTY CROSSLAND

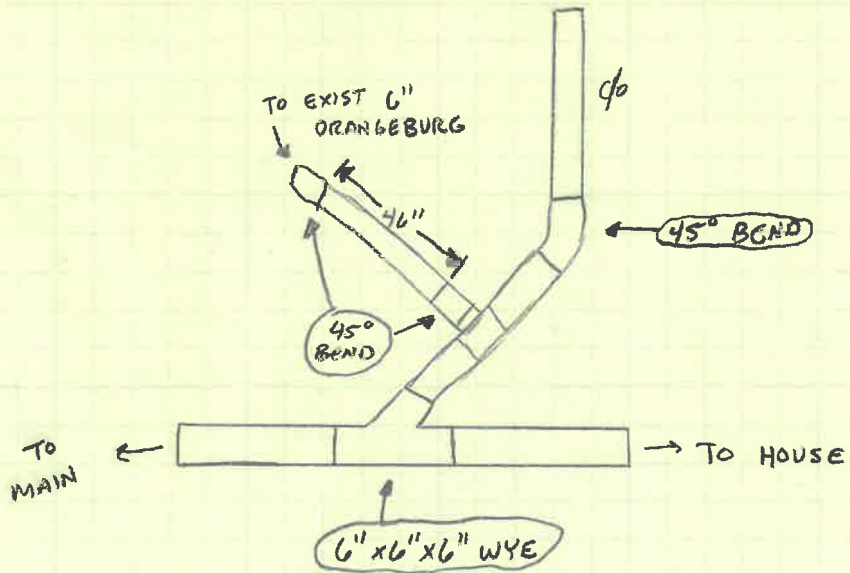
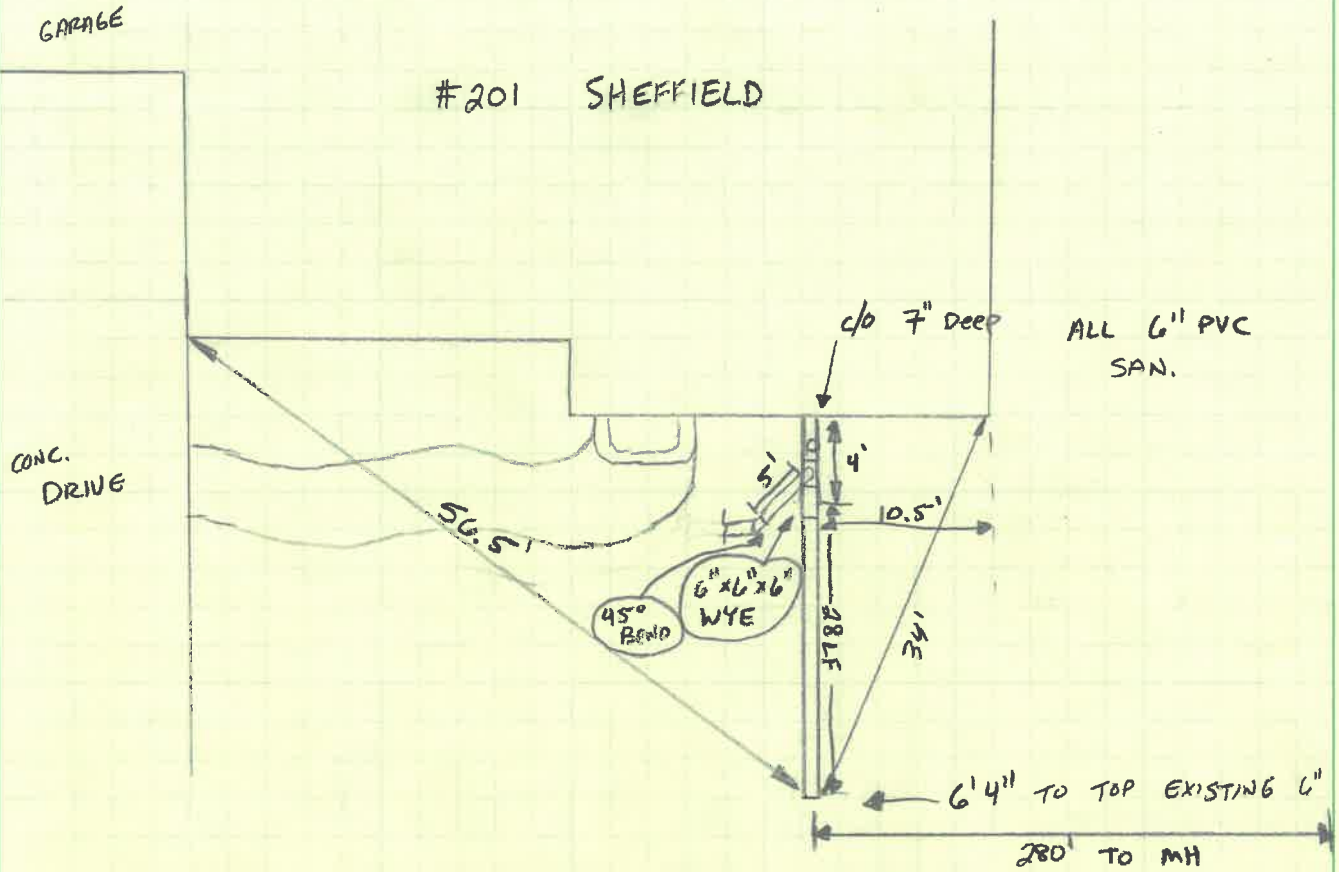



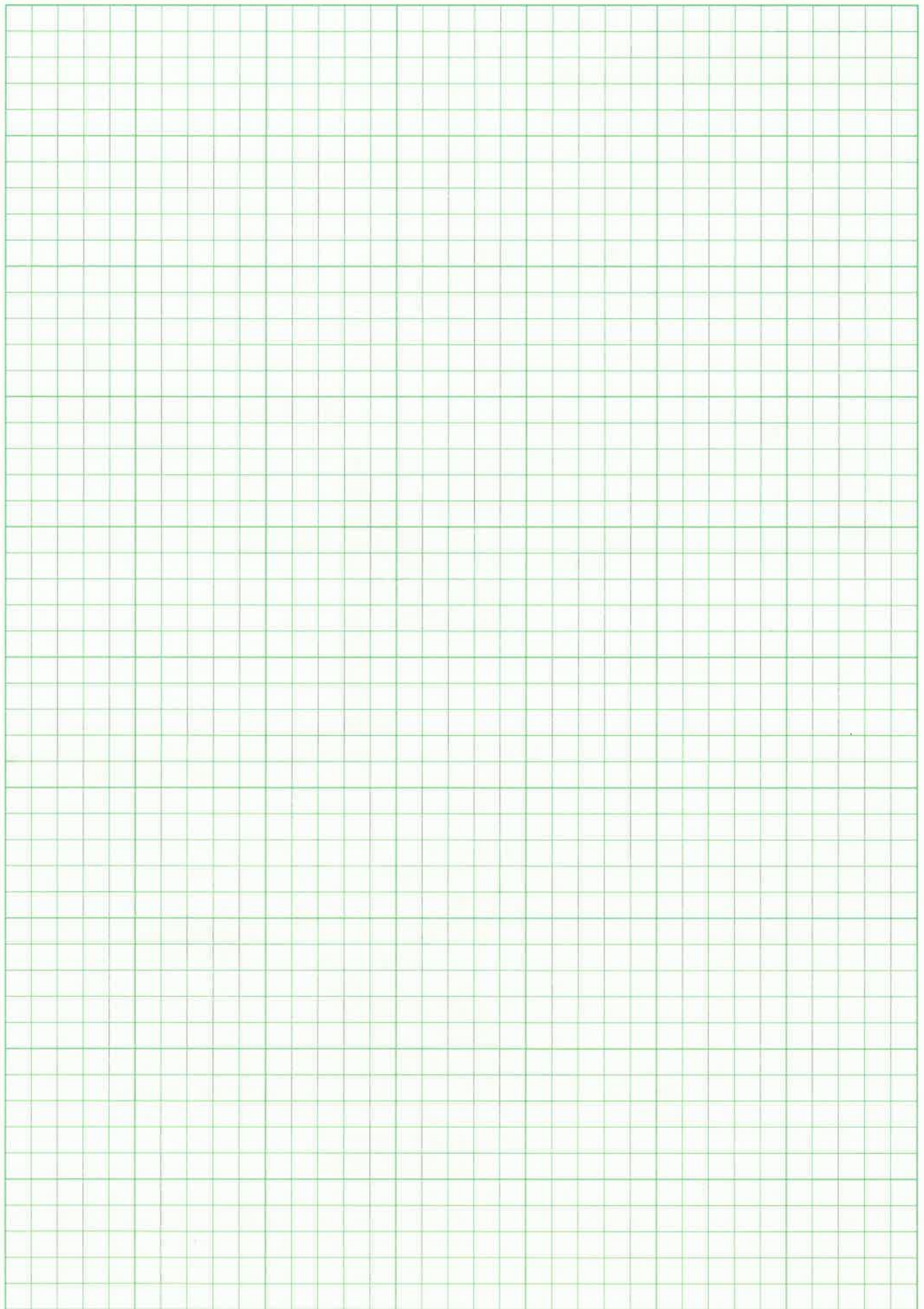





# CITY OF NAPOLEON

**BUILDING & ZONING DEPARTMENT**  
255 West Riverview Avenue, P. O. Box 151 Napoleon, OH 43545  
Tom Zimmerman, Building Commissioner/Zoning Admin  
Telephone: 419/592-4010 Fax: 419/599-8393  
[www.napoleonohio.com](http://www.napoleonohio.com)

---

January 7, 2008

Mr. Hancock & Son, LTD  
21216 State Route 34  
Stryker, OH 43557

RE: 201 Sheffield Ave.

Mr. Hancock:

This letter is in regards to my correspondence sent to you on December 10, 2007. We received the majority of the proper paperwork to register your company as a contractor to work within the city limits. We also received an application for the sewer repair permit for the above address. But we failed to receive the fee for both. As you recall the letter from December 10, stated that there is a \$25 fee for the contractor registration and another \$25 for the sewer permit. We only received \$25 which was applied to your contractor registration fee. We still need a copy of your liability insurance, which may be faxed to 419-599-8393, to complete your registration. We will also need the \$25 fee for the sewer permit for 201 Sheffield Ave.

In the event proper permits are not applied for in *advance* for any future work the City as the right to revoke your Contractor License and you would not be permitted to work within the City of Napoleon limits.

Thank you for your prompt attention to this matter. If you should have any questions feel free to give my office a call.

Thank you,

Tom Zimmerman  
Building Official

cc: file

